



DRINKWARE  
COLLECTION 2025

---

CRÉATEUR  
D'EXPÉRIENCES

---





- WINE TASTING ..... P06
- TUMBLER..... P48
- COCKTAIL, CHAMPAGNE & BEER P62
- SPIRITS ..... P78
- DECANTER ..... P86
- PRODUCT INFORMATION ..... P90

 [Click on the page you want](#)

- ABONDANCE *new* ..... P88 / 91
- ABSOLUTY ..... P50 / 91
- ARCHITECTE ..... P56-85 / 91
- CABERNET ..... P18-20-22-66-70-75 / 91
- CHAMPAGNE&COCKTAIL ..... P64-67-68 / 91
- DISTINCTION ..... P25 / 91
- ÉVIDENCE ..... P27 / 91
- EXALTATION *new* ..... P10-70 / 91
- EXPLORE ..... P88 / 91
- LADY DIAMOND ..... P38-57-67 / 91
- LIMA ..... P51-76-83 / 92
- LONGCHAMP ..... P41-57-73-85 / 92
- MACARON ..... P12-54-67-69-89 / 92
- MACARON FASCINATION ..... P69 / 92
- MACASSAR ..... P42-59-73-85 / 92
- OPENING ..... P89 / 92
- OPEN'UP ..... P14-54-70-75-89 / 92
- OPEN'UP SPIRIT ..... P80-83-84 / 92
- PRIMARY ..... P55 / 92
- PRIMARY COLOR ..... P60 / 92
- PRIMARY HANDCRAFT ..... P61 / 92
- RENDEZ-VOUS ..... P44-59-73-85 / 92
- REVEAL'UP ..... P16-70-75 / 93
- SENSATION EXALT ..... P28-72 / 93
- SÉQUENCE ..... P30-72-83 / 93
- SPIRITS ..... P81-82 / 93
- SUBLYM ..... P32-73-75 / 93
- SWIRLY *new* ..... P47-58-73 / 93
- SYMÉTRIE ..... P36-74 / 93
- VIGNE ..... P52-76-85 / 93
- VIN AU VERRE ..... P35 / 93

 Click on the page you want

Ø M = Maximum diameter.	L = Length
Ø W/O handle = Diameter without	P = Weight
H = Height	



Arc was born in the north of France, in Arques, where the Group still has its headquarters, its Research and Development division and the largest glass production site in the world.

Firmly rooted in France and its home region, Arc manufactures and distributes its products on every continent.

The Group has production sites in China, the United Arab Emirates and the United States. It operates through four brands (Cristal d'Arques Paris™, Luminarc™, Arcoroc™ and Chef&Sommelier™), bringing beauty within everyone's reach, everywhere in the world.



## Chef&Sommelier

Chef&Sommelier™ symbolizes an art of living that embodies the richness of French gastronomy and oenology.

Chef&Sommelier™ imagines glassware collections with pure and elegant design. It offers a unique signature for serving fine tables, and the demanding professionals who seek to sublimate their savoir-faire, while awakening the senses and creating unforgettable tasting experiences for guests.

The Chef&Sommelier™ collections are part of a world of innovation, passion, elegance and exacting standards.

With Chef&Sommelier™, make way for pleasure, creativity, discovery and shared authenticity! It is reassuring to know that all Chef&Sommelier™ items are produced in Krysta™, a new-generation of crystal glass, which is made in France in the "Haut de France" region.

Chef&Sommelier™ is an ARC Group brand, benefiting from the know-how and heritage of this major industrial group. It was founded in 1825 and has since become the world leader in tableware.

## CRISTAL D'ARQUES®

Since 1968, Cristal d'Arques Paris™ has embodied French elegance and beauty within everyone's reach.

While remaining true to its values, the brand now cultivates a spirit of relaxed chic, inspired by the Art Deco movement and the Parisian art of living.

Building on its expertise, Cristal d'Arques Paris™ is transforming itself by reinterpreting the codes of luxury in a spontaneous and contemporary way.

# WINE TASTING



EXPERT

● Exaltation



P 10



NEW

● Macaron



P 13

● Open'Up



P 15

● Reveal'Up Intense



P 17

● Reveal'Up Soft



P 17

UNIVERSAL

● Cabernet Abondant



P 18

● Cabernet Ballon



P 19

● Cabernet Suprême



P 19

● Cabernet Tulipe



P 20-22

● Cabernet Vins Jeunes



P 23

● Distinction



P 25

● Évidence



P 27

● Sensation Exalt



P 28

● Séquence



P 30

● Sublym



P 33

● Sublym Ballon



P 32

● Vin au verre



P 35

STRUCTURED GLASS

○ Lady Diamond



P 38

○ Longchamp



P 41

○ Macassar



P 43

○ Rendez-vous



P 45

○ Swirly



P 47

NEW

● Symétrie



P 36

● Chef & Sommelier





○ CRISTAL D'ARQUES®





## Expert Stemglasses

Classification of our Chef&Sommelier expert stemglasses according to the type of wine.

C&S EXPERTS	SPARKLING WINE	YOUNG WINE	BIO WINE	MATURE WINE
Exaltation 35cl - 30cl 	✓			
Macaron 			✓	
Open'Up 		✓		
Reveal'Up 	✓ Reveal'up Soft	✓ Reveal'up Soft		✓ Reveal'up Intense

YOUNG WINES: Whites <3 years, Reds <5 years

MATURE WINE: Whites >3 years, Reds >5 years

Click or scan



Which size of glass for which wine?

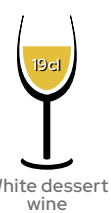



EXPERT

# Exaltation

C&S KRYSTA

\* EFFERVESCENCE PLUS

SHEER RIM



≈12,5 cl

EXALTATION  
35 cl

Ø M = 80 mm  
H = 235 mm  
W = 155 g

**Q0818**

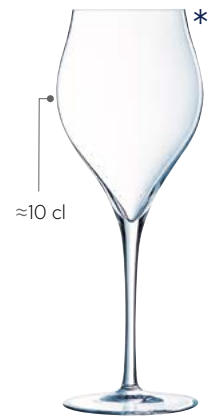

≈10 cl

EXALTATION  
30 cl

Ø M = 80 mm  
H = 211 mm  
W = 150 g

**Q1151**

**Q9945** set of 2

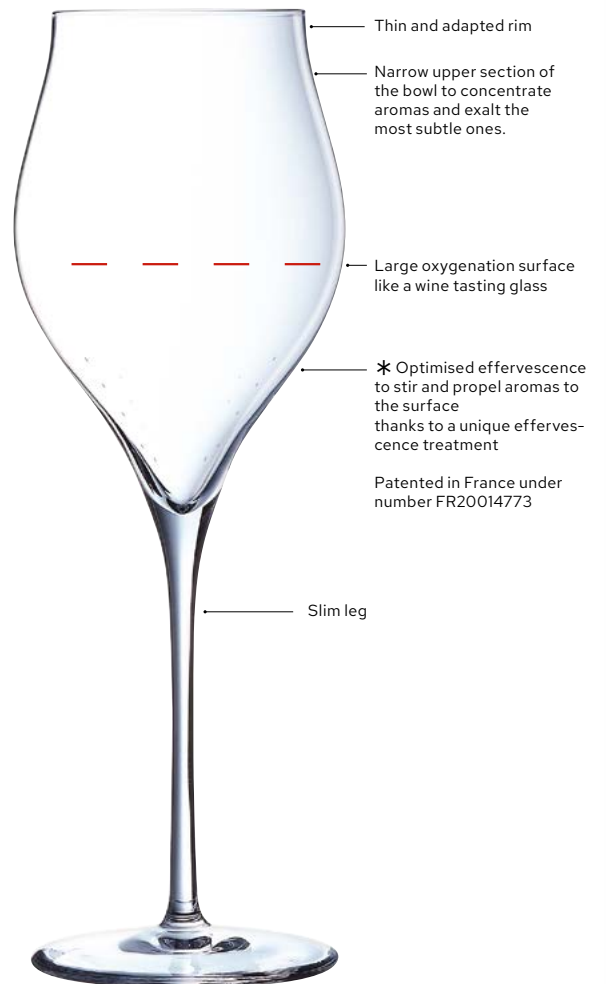

Thin and adapted rim

Narrow upper section of the bowl to concentrate aromas and exalt the most subtle ones.

Large oxygenation surface like a wine tasting glass

\* Optimised effervescence to stir and propel aromas to the surface thanks to a unique effervescence treatment

Patented in France under number FR20014773

Slim leg

Exaltation





EXALTATION  
75 cl

Ø M = 105 mm  
H = 260 mm  
W = 220 g

**V6719**



EXALTATION  
55 cl

Ø M = 95 mm  
H = 240 mm  
W = 195 g

**V6189**



EXALTATION  
47 cl

Ø M = 90 mm  
H = 225 mm  
W = 185 g

**V6190**

**V6831** set of 2



EXALTATION  
38 cl

Ø M = 90 mm  
H = 215 mm  
W = 165 g

**V6191**



Thin rim,  
for greater comfort  
during tasting

The Exaltation shape  
for still wines.

Perfect transparency to  
appreciate the colours  
of the wines.

Round and generous for  
good oxygenation of the  
wines.

A pitted base for  
a slender silhouette.

Leg stretched

Wide, flat foot,  
for greater stability,  
no water retention

*Flash the QR-code  
to see the video,  
or click directly on  
it to launch it!*



## Macaron

C&amp;S KRYSTA

SHEER RIM



MACARON  
40 cl FH

Ø M = 90 mm  
H = 105 mm  
W = 140 g

**N0834**

## Macaron

C&amp;S

MOUTH BLOWN / DROP CONTROL



MACARON  
2 L

Ø M = 163 mm  
H = 310 mm  
W = 700 g

**V6503**



Macaron

# Macaron

\* EFFERVESCENCE PLUS

C&S **KRYSTA**

SHEER RIM

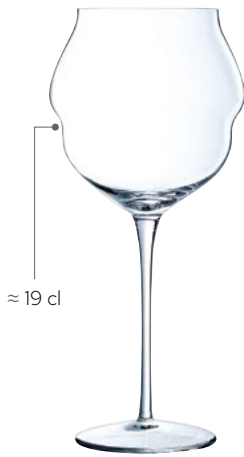

≈ 19 cl

MACARON  
60 cl

Ø M = 105 mm  
H = 235 mm  
W = 195 g

**L9414**

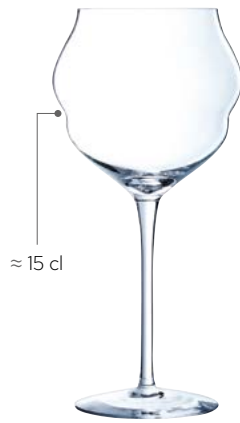

≈ 15 cl

MACARON  
50 cl

Ø M = 100 mm  
H = 215 mm  
W = 165 g

**L9412**



≈ 12,5 cl

MACARON  
40 cl

Ø M = 95 mm  
H = 200 mm  
W = 135 g

**L9267**

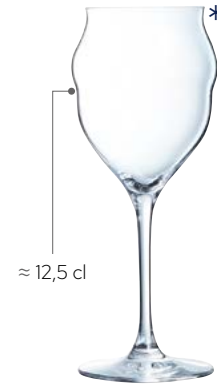

≈ 12,5 cl

MACARON  
30 cl

Ø M = 85 mm  
H = 200 mm  
W = 130 g

**L9348**



Rounded shape that hugs the lower lip perfectly for optimal comfort

Narrowed top concentrates the aromas

Usable capacity readily visible

2 differently-sized bodies that swirl the wine, allowing the less volatile aromas to surface

A non-linear design to give your table a distinctive look

Discover the Macaron stemglass, a "time accelerator".



Flash the QR-code to see the video, or click directly on it to launch it!

# Open'Up

C&S **KRYSTA**

MOUTH BLOWN / DROP CONTROL

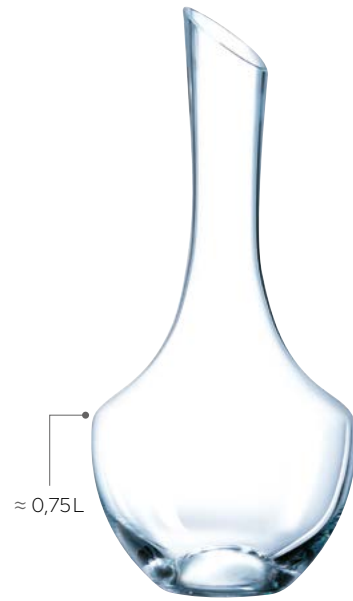

≈ 0,75L

OPEN'UP  
1,4 L

Ø M = 145 mm

H = 315 mm

W = 610 g

**D 6653**

Rounded upper part of the bowl to concentrate the aromas

Pronounced angle  
The wine molecules shatter and are oxygenated at the break point, thus releasing the aromas

Pull stem, pure and smooth lines

Flat base, means no water left on the base after washing process



Open'Up



# Open'Up

\* EFFERVESCENCE PLUS

C&S **KRYSTA**

SHEER RIM

WINE TASTING



≈ 11 cl

OPEN'UP  
55 cl TANNIC  
Ø M = 105 mm  
H = 235 mm  
W = 210 g  
**U1013**



≈ 9,5 cl

OPEN'UP  
47 cl SOFT  
Ø M = 105 mm  
H = 225 mm  
W = 210 g  
**U1012**



≈ 6 cl

OPEN'UP  
40 cl UNIVERSAL TASTING  
Ø M = 90 mm  
H = 230 mm  
W = 200 g  
**U1011**  
**Q 8625** set of 2



≈ 10 cl

OPEN'UP  
37 cl ROUND  
Ø M = 95 mm  
H = 210 mm  
W = 170 g  
**U1010**



≈ 4 cl

OPEN'UP  
32 cl PRO TASTING  
Ø M = 85 mm  
H = 180 mm  
W = 135 g  
**U1008**

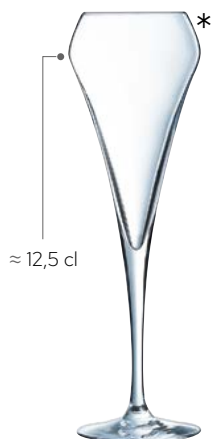

≈ 12,5 cl

OPEN'UP  
20 cl  
Ø M = 75 mm  
H = 235 mm  
W = 165 g  
**U1051**



OPEN'UP  
35 cl FH  
Ø M = 80 mm  
H = 120 mm  
W = 150 g  
**U1041**



OPEN'UP  
38 cl FB  
Ø M = 95 mm  
H = 95 mm  
W = 160 g  
**U1033**





EXPERT

# Reveal'Up

C&S **KRYSTA**

\* EFFERVESCENCE PLUS

SHEER RIM



REVEAL'UP  
21 cl

Ø M = 70 mm  
H = 235 mm  
W = 155 g

**J8907**



MACARON  
40 cl FH

Ø M = 90 mm  
H = 105 mm  
W = 140 g

**N0834**

Chimney  
to reduce the smell  
and tart taste of alcohol

Gentle angle allowing  
the oxygenation of young wines  
and revealing the aromas  
of mature wines

Usable capacity  
readily visible

Elegant narrow stem  
Very light, excellent balance  
in the hand

Extra-wide base  
provides perfect stability



Reveal'Up



# Reveal'Up

\* EFFERVESCENCE PLUS

C&S **KRYSTA**

SHEER RIM

WINE TASTING

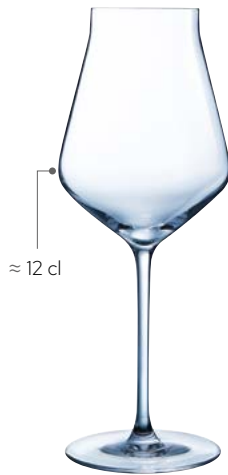

≈ 12 cl

REVEAL'UP  
50 cl SOFT

Ø M = 95 mm  
H = 245 mm  
W = 200 g

**N1738**

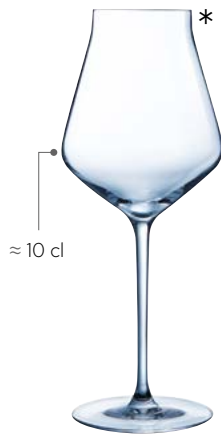

≈ 10 cl

REVEAL'UP  
40 cl SOFT

Ø M = 90 mm  
H = 230 mm  
W = 195 g

**J8743**  
**Q8623** set of 2

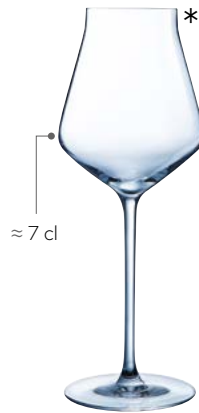

≈ 7 cl

REVEAL'UP  
30 cl SOFT

Ø M = 85 mm  
H = 215 mm  
W = 140 g

**J8908**

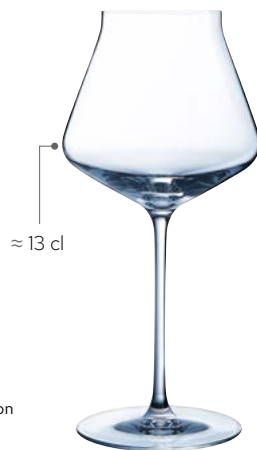

≈ 13 cl

REVEAL'UP  
55 cl INTENSE

Ø M = 110 mm  
H = 235 mm  
W = 200 g

**J9014**



≈ 10 cl

REVEAL'UP  
45 cl INTENSE

Ø M = 105 mm  
H = 220 mm  
W = 190 g

**J8742**



Smaller bowl  
for a better concentration  
of fragrances

Extra-wide oxygenation  
surface and large  
aromatic chamber  
allows the aromas  
to develop

Natural gauge

Elegant narrow stem.  
Very light, with excellent  
balance in the hand

Extra-wide base  
provides perfect stability



*Reveal'Up Intense*

Cabernet Abondant -  
Suprême

C&amp;S KRYSTA

SHEER RIM

CABERNET ABONDANT  
70 clØ M = 110 mm  
H = 220 mm  
W = 260 g**FJ037**CABERNET ABONDANT  
50 clØ M = 100 mm  
H = 200 mm  
W = 220 g**FJ038**CABERNET SUPRÊME  
62 clØ M = 95 mm  
H = 240 mm  
W = 260 g**FJ035**CABERNET SUPRÊME  
47 clØ M = 85 mm  
H = 215 mm  
W = 220 g**FJ036**

Cabernet Suprême

# Cabernet Ballon

C&S **KRYSTA**

SHEER RIM

WINE TASTING



CABERNET BALLON  
70 cl

Ø M = 115 mm  
H = 220 mm  
W = 270 g

**46981**



CABERNET BALLON  
58 cl

Ø M = 105 mm  
H = 210 mm  
W = 240 g

**47026**



CABERNET BALLON  
47 cl

Ø M = 100 mm  
H = 195 mm  
W = 190 g

**47017**



CABERNET BALLON  
35 cl

Ø M = 90 mm  
H = 180 mm  
W = 190 g

**47019**





CABERNET TULIPE  
75 cl

Ø M = 100 mm  
H = 255 mm  
W = 230 g

**D0795**



CABERNET TULIPE  
25 cl

Ø M = 70 mm  
H = 180 mm  
W = 150 g

**46978**

# Cabernet Tulipe

C&S **KRYSTA**

SHEER RIM



CABERNET TULIPE  
58 cl  
Ø M = 95 mm  
H = 230 mm  
W = 230 g  
**46888**



CABERNET TULIPE  
47 cl  
Ø M = 90 mm  
H = 220 mm  
W = 200 g  
**46961**



CABERNET TULIPE  
35 cl  
Ø M = 80 mm  
H = 205 mm  
W = 185 g  
**46973**

Also available in the  
VIN AU VERRE collection (p35)



CABERNET TULIPE  
19 cl  
Ø M = 65 mm  
H = 165 mm  
W = 145 g  
**53468**



CABERNET TULIPE  
12 cl  
Ø M = 55 mm  
H = 150 mm  
W = 105 g  
**14798**



CABERNET TULIPE  
7 cl  
Ø M = 50 mm  
H = 135 mm  
W = 80 g  
**E5358**





## Cabernet

C&amp;S KRYSTA

\* EFFERVESCENCE PLUS

SHEER RIM

CABERNET  
47 clØ M = 80 mm  
H = 190 mm  
W = 240 g**G 3570**CABERNET  
40 clØ M = 80 mm  
H = 170 mm  
W = 195 g**G 3573**CABERNET  
24 clØ M = 70 mm  
H = 235 mm  
W = 140 g**D 0796**CABERNET  
16 clØ M = 70 mm  
H = 225 mm  
W = 145 g**48024**



# Cabernet Vins jeunes

C&S **KRYSTA**

SHEER RIM



≈19 cl

CABERNET VINS JEUNES  
58 cl

Ø M = 105 mm  
H = 225 mm  
W = 210 g

**E2789**



≈15 cl

CABERNET VINS JEUNES  
47 cl

Ø M = 100 mm  
H = 215 mm  
W = 190 g

**E2790**



≈10 cl

CABERNET VINS JEUNES  
35 cl

Ø M = 90 mm  
H = 200 mm  
W = 165 g

**E2788**

Also available in the  
VIN AU VERRE collection (p35)

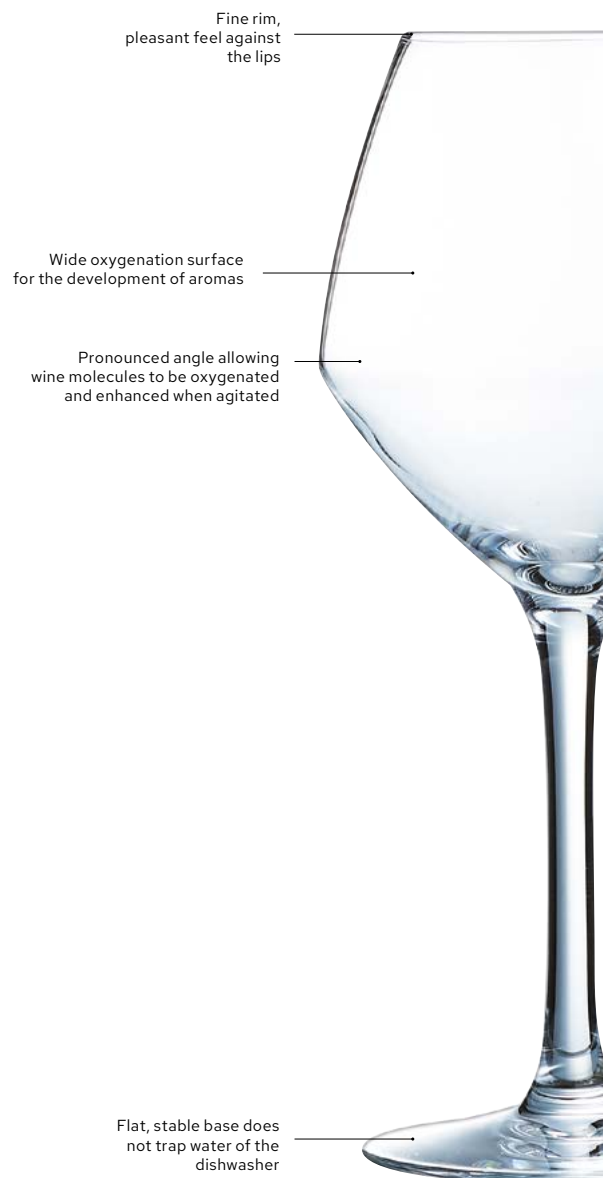

Fine rim,  
pleasant feel against  
the lips

Wide oxygenation surface  
for the development of aromas

Pronounced angle allowing  
wine molecules to be oxygenated  
and enhanced when agitated

Flat, stable base does  
not trap water of the  
dishwasher



*Distinction*

## Distinction

\* EFFERVESCENCE PLUS

C&amp;S KRYSTA

SHEER RIM



DISTINCTION  
47 cl

Ø M = 95 mm  
H = 235 mm  
W = 185 g

**Q9064**



DISTINCTION  
38 cl

Ø M = 90 mm  
H = 220 mm  
W = 175 g

**Q9062**



DISTINCTION  
28 cl

Ø M = 85 mm  
H = 210 mm  
W = 150 g

**Q8990**



DISTINCTION  
23 cl

Ø M = 70 mm  
H = 235 mm  
W = 130 g

**Q9080**



*Evidence*



## Évidence

\* EFFERVESCENCE PLUS

C&amp;S KRYSTA

SHEER RIM



ÉVIDENCE  
45 cl

Ø M = 85 mm  
H = 210 mm  
W = 180 g

**V2821**



ÉVIDENCE  
35 cl

Ø M = 80 mm  
H = 190 mm  
W = 140 g

**V2620**



ÉVIDENCE  
27 cl

Ø M = 75 mm  
H = 180 mm  
W = 120 g

**V2822**



ÉVIDENCE  
16 cl

Ø M = 65 mm  
H = 190 mm  
W = 140 g

**V2823**





UNIVERSAL

Sensation Exalt

C&S KRYSTA

\* EFFERVESCENCE PLUS

SHEER RIM



SENSATION EXALT  
19 cl

Ø M = 70 mm  
H = 210 mm  
W = 170 g

**E7700**

Sensation Exalt





SENSATION EXALT  
41 cl  
Ø M = 90 mm  
H = 205 mm  
W = 270 g  
**E 7695**



SENSATION EXALT  
31 cl  
Ø M = 80 mm  
H = 200 mm  
W = 220 g  
**E 7696**



SENSATION EXALT  
25 cl  
Ø M = 75 mm  
H = 190 mm  
W = 165 g  
**E 7697**



SENSATION EXALT  
20 cl  
Ø M = 70 mm  
H = 180 mm  
W = 160 g  
**E 7698**

A thin, tall rim with an enclosed opening

A gentle angle, capable of oxygenating young wines and preserving mature wines

A highly resistant stem, perfectly suited to intensive use

Flat and stable base, no water retention when removed from the dishwasher



## Séquence

C&amp;S KRISTA

\* EFFERVESCENCE PLUS

SHEER RIM



Séquence

SÉQUENCE  
17 cl

Ø M = 70 mm  
H = 210 mm  
W = 135 g

**L9947**SÉQUENCE  
24 cl IMPÉRIALE

Ø M = 70 mm  
H = 235 mm  
W = 155 g

**P3787**



SÉQUENCE  
74 cl  
Ø M = 100 mm  
H = 235 mm  
W = 200 g  
**L9951**



SÉQUENCE  
62 cl  
Ø M = 95 mm  
H = 235 mm  
W = 210 g  
**N9710**



SÉQUENCE  
55 cl  
Ø M = 90 mm  
H = 235 mm  
W = 190 g  
**L9950**



SÉQUENCE  
44 cl  
Ø M = 90 mm  
H = 225 mm  
W = 180 g  
**L9949**



SÉQUENCE  
35 cl  
Ø M = 80 mm  
H = 210 mm  
W = 155 g  
**L9948**



A generous bowl that concentrates aromas and allows a very precise relationship between mouth, glass and wine

Well proportioned, practical stem

Flat, stable base does not retain water after dishwashing



SÉQUENCE  
21 cl PORTO  
Ø M = 65 mm  
H = 190 mm  
W = 115 g  
**N9696**



SÉQUENCE  
37 cl BIÈRE  
Ø M = 80 mm  
H = 150 mm  
W = 130 g  
**P0089**



SÉQUENCE  
47 cl MULTI-USAGE  
Ø M = 85 mm  
H = 180 mm  
W = 165 g  
**N9711**





SUBLYM  
60 cl BALLON

---

Ø M = 110 mm  
H = 230 mm  
W = 210 g  
**N4742**



Sublym

When the wine is agitated,  
it rises vertically,  
expressing its aromas in  
successive layers

Perfectly continuous  
glass profile

Flat, stable base  
does not trap water  
of the dishwasher







SUBLYM  
55 cl  
Ø M = 90 mm  
H = 260 mm  
W = 220 g  
**V3604**



SUBLYM  
45 cl  
Ø M = 90 mm  
H = 250 mm  
W = 210 g  
**N1739**



SUBLYM  
35 cl  
Ø M = 80 mm  
H = 230 mm  
W = 175 g  
**L2761**



SUBLYM  
25 cl  
Ø M = 70 mm  
H = 210 mm  
W = 150 g  
**L2609**



SUBLYM  
21 cl  
Ø M = 65 mm  
H = 240 mm  
W = 140 g  
**L2762**



SUBLYM  
35 cl MULTI-USAGE  
Ø M = 80 mm  
H = 180 mm  
W = 175 g  
**N5368**





*Vin au verre*

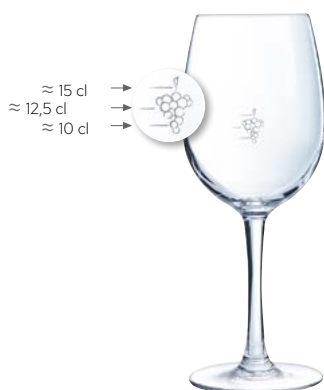

VIN AU VERRE  
35 cl CABERNET TULIPE GRAPPE

Ø M = 80 mm  
H = 205 mm  
W = 185 g

**P9026**



VIN AU VERRE  
35 cl CABERNET TULIPE ELLIPSE

Ø M = 80 mm  
H = 205 mm  
W = 185 g

**J4587**

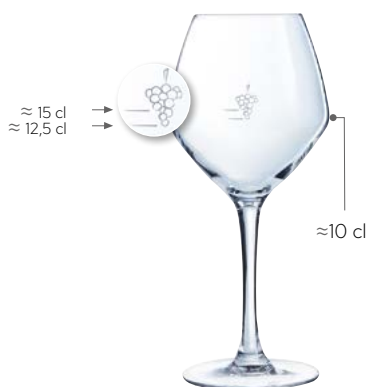

VIN AU VERRE  
35 cl CABERNET VINS JEUNES GRAPPE

Ø M = 90 mm  
H = 200 mm  
W = 165 g

**P8619**



# Symétrie

C&S **KRYSTA**

\* EFFERVESCENCE PLUS

SHEER RIM



SYMÉTRIE  
21 cl

Ø M = 115 mm  
H = 180 mm  
W = 170 g

**V1171**

Symétrie



# Symétrie

\* EFFERVESCENCE PLUS

C&S **KRYSTA**

SHEER RIM



SYMÉTRIE  
58 cl

Ø M = 105 mm  
H = 210 mm  
W = 240 g

**Q8707**



SYMÉTRIE  
21 cl

Ø M = 65 mm  
H = 240 mm  
W = 140 g

**V2697**



SYMÉTRIE  
16 cl

Ø M = 65 mm  
H = 200 mm  
W = 130 g

**V1375**



SYMÉTRIE  
55 cl

Ø M = 90 mm  
H = 260 mm  
W = 220 g

**V2696**



SYMÉTRIE  
45 cl

Ø M = 90 mm  
H = 250 mm  
W = 210 g

**V0391**



SYMÉTRIE  
35 cl

Ø M = 80 mm  
H = 230 mm  
W = 180 g

**V1483**





LADY DIAMOND  
36 cl FH

Ø M = 70 mm  
H = 130 mm  
W = 400 g

**L9746**

**V5468** set of 4



LADY DIAMOND  
27 cl FB

Ø M = 90 mm  
H = 90 mm  
W = 270 g

**L9747**

**V4485** set of 4



LADY DIAMOND  
27 cl

Ø M = 90 mm  
H = 210 mm  
W = 360 g

**L9743**

**V4483** set of 4



LADY DIAMOND  
19 cl

Ø M = 80 mm  
H = 200 mm  
W = 310 g

**L9744**

**V4484** set of 4



LADY DIAMOND  
15 cl

Ø M = 75 mm  
H = 230 mm  
W = 290 g

**L9742**

**V8228** set of 4







Longchamp





LONGCHAMP  
25 cl

Ø M = 75 mm  
H = 180 mm  
W = 340 g

**L7550**

**V4704** set of 4



LONGCHAMP  
17 cl

Ø M = 70 mm  
H = 165 mm  
W = 235 g

**L7552**

**V4702** set of 4



LONGCHAMP  
6 cl

Ø M = 49 mm  
H = 115 mm  
W = 95 g

**L 9754**



LONGCHAMP  
14 cl

Ø M = 65 mm  
H = 205 mm  
W = 270 g

**L7553**

**V4705** set of 4



LONGCHAMP  
32 cl

Ø M = 90 mm  
H = 130 mm  
W = 220 g

**L9755**

**V7389** set of 4



LONGCHAMP  
36 cl FH

Ø M = 80 mm  
H = 135 mm  
W = 410 g

**L9557**

**V7383** set of 4



LONGCHAMP  
28 cl FH

Ø M = 65 mm  
H = 130 mm  
W = 300 g

**L7554**

**V7384** set of 4



LONGCHAMP  
32 cl FB

Ø M = 56 mm  
H = 95 mm  
W = 290 g

**L7555**

**V4700** set of 4



LONGCHAMP  
23 cl FB

Ø M = 75 mm  
H = 90 mm  
W = 240 g

**L9758**

**V7385** set of 4



LONGCHAMP  
4,5 cl FB HOT SHOT

Ø M = 26 mm  
H = 57 mm  
W = 70 g

**L9756**



Macassar

MACASSAR  
36 cl FH

Ø M = 85 mm  
H = 130 mm  
W = 440 g

**Q4340**  
**V7376** set of 4

MACASSAR  
32 cl FB

Ø M = 95 mm  
H = 100 mm  
W = 430 g

**Q4337**  
**V7377** set of 4

MACASSAR  
6 cl FB

Ø M = 50 mm  
H = 80 mm  
W = 120 g

**Q4342**



MACASSAR  
35 cl  
Ø M = 95 mm  
H = 210 mm  
W = 300 g  
**Q4331**  
**V7374** set of 4



MACASSAR  
25 cl  
Ø M = 85 mm  
H = 200 mm  
W = 250 g  
**Q4346**  
**V7375** set of 4



MACASSAR  
17 cl  
Ø M = 60 mm  
H = 235 mm  
W = 210 g  
**Q4335**  
**V7373** set of 4







RENDEZ-VOUS  
36 cl FH

Ø M = 85 mm  
H = 130 mm  
W = 435 g

**V7381** set of 4



RENDEZ-VOUS  
32 cl FB

Ø M = 90 mm  
H = 95 mm  
W = 390 g

**V7382** set of 4





RENDEZ-VOUS  
35 cl  
Ø M = 95 mm  
H = 215 mm  
W = 405 g  
**V7379** set of 4



RENDEZ-VOUS  
25 cl  
Ø M = 85 mm  
H = 200 mm  
W = 260 g  
**V7380** set of 4



RENDEZ-VOUS  
17 cl  
Ø M = 65 mm  
H = 220 mm  
W = 260 g  
**V7378** set of 4





Swirly

## Swirly

 CRISTALLIN

NEW



SWIRLY  
47 cl

Ø M = 95 mm  
H = 230 mm  
W = 200 g

**V2820** set of 4



SWIRLY  
35 cl

Ø M = 85 mm  
H = 210 mm  
W = 155 g

**V2829** set of 4



SWIRLY  
24 cl

Ø M = 70 mm  
H = 235 mm  
W = 155 g

**V2830** set of 4



SWIRLY  
36 cl FH

Ø M = 80 mm  
H = 100 mm  
W = 155 g

**V2831** set of 4



# TUMBLER

BAR & TABLE





HEAVY BASE

● Absoluty



P 50

● Lima



P 51

● Vigne



P 52

THIN BASE

● Macaron



P 54

● Open'Up



P 54

● Primary



P 55

STRUCTURED

○ Architecte



P 56

○ Lady Diamond



P 57

○ Longchamp



P 57

○ Macassar



P 59

○ Rendez-vous



P 59

○ Swirly



P 58

NEW

COLORED

● Primary Color



P 60

● Primary Handcraft



P 61

● Chef&Sommelier

○ CRISTAL D'ARQUES®



ABSOLUTY  
45 cl FH

Ø M = 85 mm  
H = 130 mm  
W = 220 g

**Q9217**



ABSOLUTY  
37 cl FH

Ø M = 80 mm  
H = 120 mm  
W = 190 g

**Q9216**



ABSOLUTY  
32 cl FB

Ø M = 85 mm  
H = 90 mm  
W = 175 g

**Q9214**



ABSOLUTY  
25 cl FB

Ø M = 80 mm  
H = 85 mm  
W = 150 g

**Q9215**





LIMA  
45 cl FH  
Ø M = 80 mm  
H = 160 mm  
W = 250 g  
**L 2356**



LIMA  
40 cl FH  
Ø M = 80 mm  
H = 135 mm  
W = 240 g  
**L 8110**



LIMA  
38 cl FH  
Ø M = 90 mm  
H = 110 mm  
W = 220 g  
**G 3368**



LIMA  
35 cl FB  
Ø M = 95 mm  
H = 85 mm  
W = 225 g  
**G 3367**



Lima



VIGNE  
37 cl FB

Ø M = 95 mm  
H = 90 mm  
W = 380 g

**L 2370**



VIGNE  
31 cl FB

Ø M = 85 mm  
H = 85 mm  
W = 260 g

**G 3666**



VIGNE  
20 cl FB

Ø M = 75 mm  
H = 75 mm  
W = 220 g

**G 3659**







VIGNE  
45 cl FH  
Ø M = 70 mm  
H = 165 mm  
W = 310 g  
**L 2369**



VIGNE  
33 cl FH  
Ø M = 70 mm  
H = 125 mm  
W = 240 g  
**G 3674**



VIGNE  
22 cl FH  
Ø M = 60 mm  
H = 110 mm  
W = 190 g  
**G 3658**

Fine rim  
pleasant feel against the lips

Timeless design  
Suitable for bars  
classic or trendy

Heavy base for stability  
that reflects the colours  
of the drinks



# Macaron

C&S **KRYSTA**

SHEER RIM



MACARON  
40 cl FH

Ø M = 85 mm  
H = 105 mm  
W = 140 g

**N0834**

# Open'Up

C&S **KRYSTA**

SHEER RIM



OPEN'UP  
35 cl FH

Ø M = 80 mm  
H = 120 mm  
W = 150 g

**U1041**



OPEN'UP  
38 cl FB

Ø M = 95 mm  
H = 95 mm  
W = 155 g

**U1033**



Macaron



PRIMARY  
44 cl FH  
Ø M = 90 mm  
H = 110 mm  
W = 155 g  
**G3323**



PRIMARY  
40 cl FH  
Ø M = 75 mm  
H = 130 mm  
W = 150 g  
**L8677**



PRIMARY  
36 cl FH  
Ø M = 80 mm  
H = 100 mm  
W = 155 g  
**G3322**



PRIMARY  
27 cl FH  
Ø M = 75 mm  
H = 95 mm  
W = 125 g  
**G0036**

This elegant line is practical for upmarket restaurants, as it can be used for everything from drinks and cocktails to trendy decorative presentations of starters and desserts.





STRUCTURED

# Architecte

 CRISTALLIN



ARCHITECTE  
36 cl FH  
Ø M = 85 mm  
H = 130 mm  
W = 390 g  
**V7386** set of 4



ARCHITECTE  
32 cl FB  
Ø M = 95 mm  
H = 100 mm  
W = 410 g  
**V7387** set of 4



ARCHITECTE  
6 cl FB  
Ø M = 49 mm  
H = 78,5 mm  
W = 120 g  
**Q4367**

Architecte

SUMMARY  



## Lady Diamond

 CRISTALLIN



LADY DIAMOND  
36 cl FH  
Ø M = 70 mm  
H = 130 mm  
W = 400 g  
**L9746**  
**V5468** set of 4



LADY DIAMOND  
27 cl FB  
Ø M = 90 mm  
H = 90 mm  
W = 270 g  
**L9747**  
**V4485** set of 4

## Longchamp

 CRISTALLIN



LONGCHAMP  
36 cl FH  
Ø M = 80 mm  
H = 135 mm  
W = 410 g  
**L9757**  
**V7383** set of 4



LONGCHAMP  
32 cl FB  
Ø M = 56 mm  
H = 95 mm  
W = 290 g  
**L7555**  
**V4700** set of 4



LONGCHAMP  
4,5 cl FB HOT SHOT  
Ø M = 46 mm  
H = 57 mm  
W = 70 g  
**L9756**



SWIRLY  
36 cl FH

Ø M = 80 mm  
H = 100 mm  
W = 155 g

**V2831** set of 4



MACASSAR  
36 cl FH  
Ø M = 85 mm  
H = 130 mm  
W = 440 g  
**Q4340**  
**V7376** set of 4



MACASSAR  
32 cl FB  
Ø M = 95 mm  
H = 99 mm  
W = 430 g  
**Q4337**  
**V7377** set of 4



MACASSAR  
6 cl FB  
Ø M = 50 mm  
H = 80 mm  
W = 120 g  
**Q4342**



RENDEZ-VOUS  
36 cl FH  
Ø M = 85 mm  
H = 130 mm  
W = 435 g  
**V7381** set of 4



RENDEZ-VOUS  
32 cl FB  
Ø M = 90 mm  
H = 95 mm  
W = 390 g  
**V7382** set of 4



# Primary Color

C&S **KRYSTA**

SHEER RIM / PROFESSIONAL 2000 CYCLES



PRIMARY COLOR  
36 cl FH EMERALD  
Ø M = 80 mm  
H = 100 mm  
W = 155 g  
**V3051**



PRIMARY COLOR  
36 cl FH JADE  
Ø M = 80 mm  
H = 100 mm  
W = 155 g  
**V3052**



PRIMARY COLOR  
36 cl FH BLACK MAT  
Ø M = 80 mm  
H = 100 mm  
W = 155 g  
**L9406**



PRIMARY COLOR  
36 cl FH WHITE MAT  
Ø M = 80 mm  
H = 100 mm  
W = 155 g  
**L9407**







PRIMARY HANDCRAFT  
36 cl FH BLUE

Ø M = 80 mm  
H = 100 mm  
W = 155 g

**Q3478**



PRIMARY HANDCRAFT  
36 cl FH GREY

Ø M = 80 mm  
H = 100 mm  
W = 155 g

**Q3477**



PRIMARY HANDCRAFT  
36 cl FH RED

Ø M = 80 mm  
H = 100 mm  
W = 155 g

**Q3215**



# COCKTAIL, CHAMPAGNE & BEER



MARTINI SHAPE



P 64

HURRICANE SHAPE



P 65

GIN SHAPE



P 66

SPECIAL SHAPE



P 67

CHAMPAGNE TASTING



P 68 - 70 - 72

STRUCTURED FLUTE



P 73 - 74

BEER TASTING



P 75 - 76

COCKTAIL, CHAMPAGNE  
& BEER



# Champagne & Cocktail

C&S **KRYSTA**

\* EFFERVESCENCE PLUS

SHEER RIM



CHAMPAGNE & COCKTAIL  
30 cl

Ø M = 120 mm

H = 170 mm

W = 175 g

**N 6815**



Champagne & Cocktail 30 cl



## Champagne & Cocktail

\* EFFERVESCENCE PLUS

C&S **KRYSTA**

SHEER RIM



CHAMPAGNE & COCKTAIL  
30 cl

Ø M = 120 mm  
H = 190 mm  
W = 220 g

**N6831**



CHAMPAGNE & COCKTAIL  
21 cl

Ø M = 115 mm  
H = 170 mm  
W = 190 g

**N6887**



CHAMPAGNE & COCKTAIL  
21 cl

Ø M = 115 mm  
H = 180 mm  
W = 170 g

**L3678**



CHAMPAGNE & COCKTAIL  
21 cl

Ø M = 95 mm  
H = 150 mm  
W = 100 g

**Q7785**

HURRICANE SHAPE

## Champagne & Cocktail

C&S **KRYSTA**

SHEER RIM



CHAMPAGNE & COCKTAIL  
44 cl

Ø M = 80 mm  
H = 210 mm  
W = 225 g

**V3263**

COCKTAIL, CHAMPAGNE  
& BEER

## Cabernet Abondant

C&S **KRYSTA**

SHEER RIM



CABERNET ABONDANT  
70 cl

Ø M = 110 mm

H = 220 mm

W = 260 g

**F J037**

## Macaron

C&S **KRYSTA**

SHEER RIM



MACARON  
60 cl

Ø M = 105 mm

H = 235 mm

W = 195 g

**L 9414**

## Cabernet Ballon

C&S **KRYSTA**

SHEER RIM



CABERNET BALLON  
70 cl

Ø M = 115 mm  
H = 220 mm  
W = 270 g

**46981**

## Cabernet Suprême

C&S **KRYSTA**

SHEER RIM



CABERNET SUPRÊME  
62 cl

Ø M = 95 mm  
H = 240 mm  
W = 260 g

**FJ035**

## Spirits

C&S **KRYSTA**

SHEER RIM



SPIRITS  
70 cl

Ø M = 115 mm  
H = 160 mm  
W = 200 g

**N8172**

## Champagne & Cocktail

C&S **KRYSTA**

SHEER RIM



CHAMPAGNE & COCKTAIL  
15 cl NICK & NORA

Ø M = 70 mm  
H = 145 mm  
W = 100 g

**Q3702**

SPECIAL SHAPE

COCKTAIL, CHAMPAGNE  
& BEER



Macaron



CHAMPAGNE & COCKTAIL  
21 cl

Ø M = 115 mm  
H = 180 mm  
W = 170 g

**L3678**



CHAMPAGNE & COCKTAIL  
30 cl

Ø M = 120 mm  
H = 170 mm  
W = 175 g

**N6815**



CHAMPAGNE & COCKTAIL  
21 cl

Ø M = 95 mm  
H = 150 mm  
W = 100 g

**Q7785**



# Macaron

C&S **KRYSTA**

EFFERVESCENCE PLUS / SHEER RIM

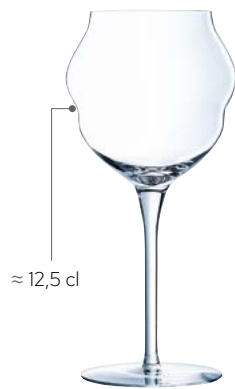

≈ 12,5 cl

MACARON  
40 cl

Ø M = 95 mm  
H = 200 mm  
W = 135 g

**L9267**

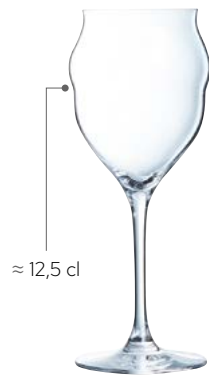

≈ 12,5 cl

MACARON  
30 cl

Ø M = 85 mm  
H = 200 mm  
W = 130 g

**L9348**

# Macaron Fascination

C&S **KRYSTA**

EFFERVESCENCE PLUS / SHEER RIM



MACARON FASCINATION  
30 cl

Ø M = 95 mm  
H = 190 mm  
W = 135 g

**N6386**

Macaron

COCKTAIL, CHAMPAGNE  
& BEER

# Exaltation

C&S **KRYSTA**

EFFERVESCENCE PLUS / SHEER RIM



EXALTATION  
35 cl

Ø M = 80 mm  
H = 235 mm  
W = 155 g

**Q0818**



EXALTATION  
30 cl

Ø M = 80 mm  
H = 210 mm  
W = 150 g

**Q1151**

**Q9945** set of 2

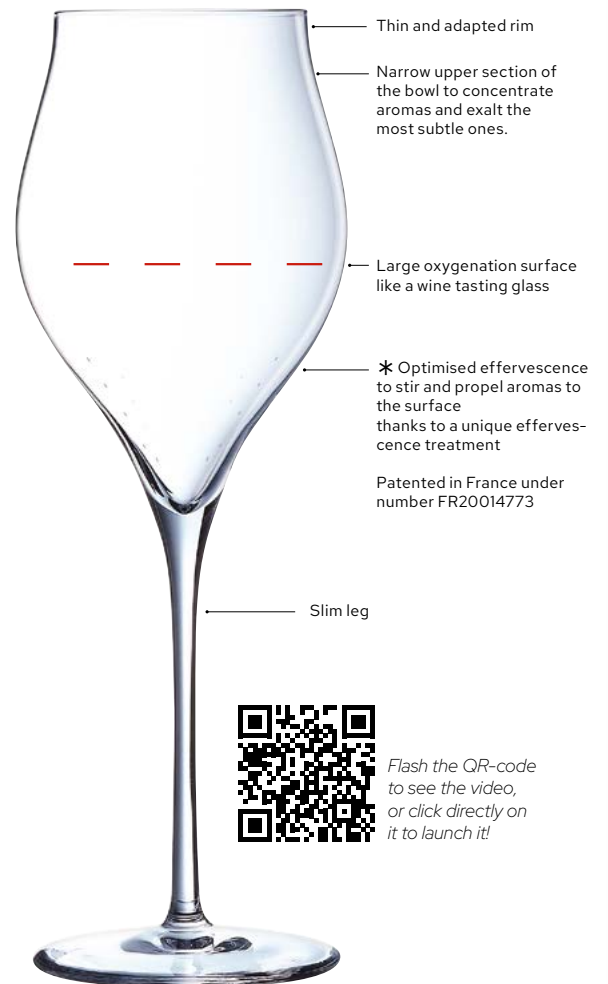

Flash the QR-code to see the video, or click directly on it to launch it!

Exaltation

## Cabernet

C&S KRYSTA

EFFERVESCENCE PLUS / SHEER RIM



CABERNET  
24 cl GRAND CHAMPAGNE

Ø M = 70 mm  
H = 235 mm  
W = 145 g

**D0796**



CABERNET  
16 cl COCKTAIL

Ø M = 70 mm  
H = 225 mm  
W = 145 g

**48024**

## Open'Up

C&S KRYSTA

EFFERVESCENCE PLUS / SHEER RIM



≈ 12,5 cl

OPEN'UP  
20 cl

Ø M = 75 mm  
H = 235 mm  
W = 165 g

**U1051**

## Reveal'Up

C&S KRYSTA

EFFERVESCENCE PLUS / SHEER RIM



REVEAL'UP  
21 cl

Ø M = 70 mm  
H = 235 mm  
W = 155 g

**J8907**



REVEAL'UP  
40 cl SOFT

Ø M = 90 mm  
H = 230 mm  
W = 195 g

**J8743**



REVEAL'UP  
30 cl SOFT

Ø M = 85 mm  
H = 220 mm  
W = 140 g

**J8908**



Reveal'Up



## Séquence

C&S KRYSTA

EFFERVESCENCE PLUS / SHEER RIM



SÉQUENCE  
24 cl IMPERIALE  
Ø M = 70 mm  
H = 235 mm  
W = 155 g  
**P3787**



SÉQUENCE  
17 cl  
Ø M = 55 mm  
H = 210 mm  
W = 135 g  
**L9947**

## Sensation Exalt

C&S KRYSTA

EFFERVESCENCE PLUS / SHEER RIM



SENSATION EXALT  
19 cl  
Ø M = 70 mm  
H = 210 mm  
W = 170 g  
**E7700**

Swirly



## Sublym

C&S **KRYSTA**

EFFERVESCENCE PLUS / SHEER RIM



SUBLYM  
21 cl

Ø M = 70 mm  
H = 240 mm  
W = 140 g

**L2762**

## Lady Diamond

**CRISTALLIN**



LADY DIAMOND  
15 cl

Ø M = 75 mm  
H = 230 mm  
W = 290 g

**L9742**

**V8228** set of 4

STRUCTURED FLUTE

COCKTAIL, CHAMPAGNE  
& BEER

STRUCTURED FLUTE

## Longchamp

## Macassar

## Rendez-vous

## Swirly

**CRISTALLIN**



LONGCHAMP  
14 cl

Ø M = 65 mm  
H = 205 mm  
W = 270 g

**L7553**

**V4705** set of 4



MACASSAR  
17 cl

Ø M = 60 mm  
H = 235 mm  
W = 210 g

**Q4335**

**V7373** set of 4



RENDEZ-VOUS  
17 cl

Ø M = 65 mm  
H = 220 mm  
W = 260 g

**V7378** set of 4



NEW

SWIRLY  
24 cl

Ø M = 70 mm  
H = 235 mm  
W = 155 g

**V2830** set of 4

Symétrie

C&amp;S KRISTA

EFFERVESCENCE PLUS / SHEER RIM



Symétrie

SYMÉTRIE  
21 cl

---

 Ø M = 65 mm  
 H = 240 mm  
 W = 140 g
**V2697**SYMÉTRIE  
16 cl

---

 Ø M = 65 mm  
 H = 200 mm  
 W = 130 g
**V1375**

## Cabernet Vins jeunes

C&S **KRYSTA**  
SHEER RIM



CABERNET VINS JEUNES  
47 cl  
Ø M = 100 mm  
H = 215 mm  
W = 190 g  
**E2790**

## Open'Up

C&S **KRYSTA**  
SHEER RIM



OPEN'UP  
47 cl SOFT  
Ø M = 105 mm  
H = 225 mm  
W = 210 g  
**U1012**

## Reveal'Up

C&S **KRYSTA**  
EFFERVESCENCE PLUS / SHEER RIM

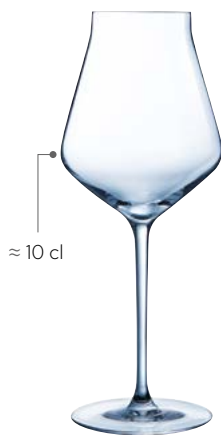

REVEAL'UP  
40 cl SOFT  
Ø M = 90 mm  
H = 230 mm  
W = 195 g  
**J8743**  
**Q8623** set of 2

## Sublym

C&S **KRYSTA**  
SHEER RIM



SUBLYM  
45 cl  
Ø M = 90 mm  
H = 250 mm  
W = 210 g  
**N1739**



Séquence

## Séquence

C&S **KRYSTA**

SHEER RIM



SÉQUENCE  
37 cl

Ø M = 80 mm  
H = 150 mm  
W = 130 g

**P0089**

## Lima

C&S **KRYSTA**

SHEER RIM



LIMA  
45 cl FH

Ø M = 80 mm  
H = 160 mm  
W = 250 g

**L2356**

## Vigne

C&S **KRYSTA**

SHEER RIM



VIGNE  
45 cl FH

Ø M = 70 mm  
H = 165 mm  
W = 310 g

**L2369**



# Which glass for which beer?

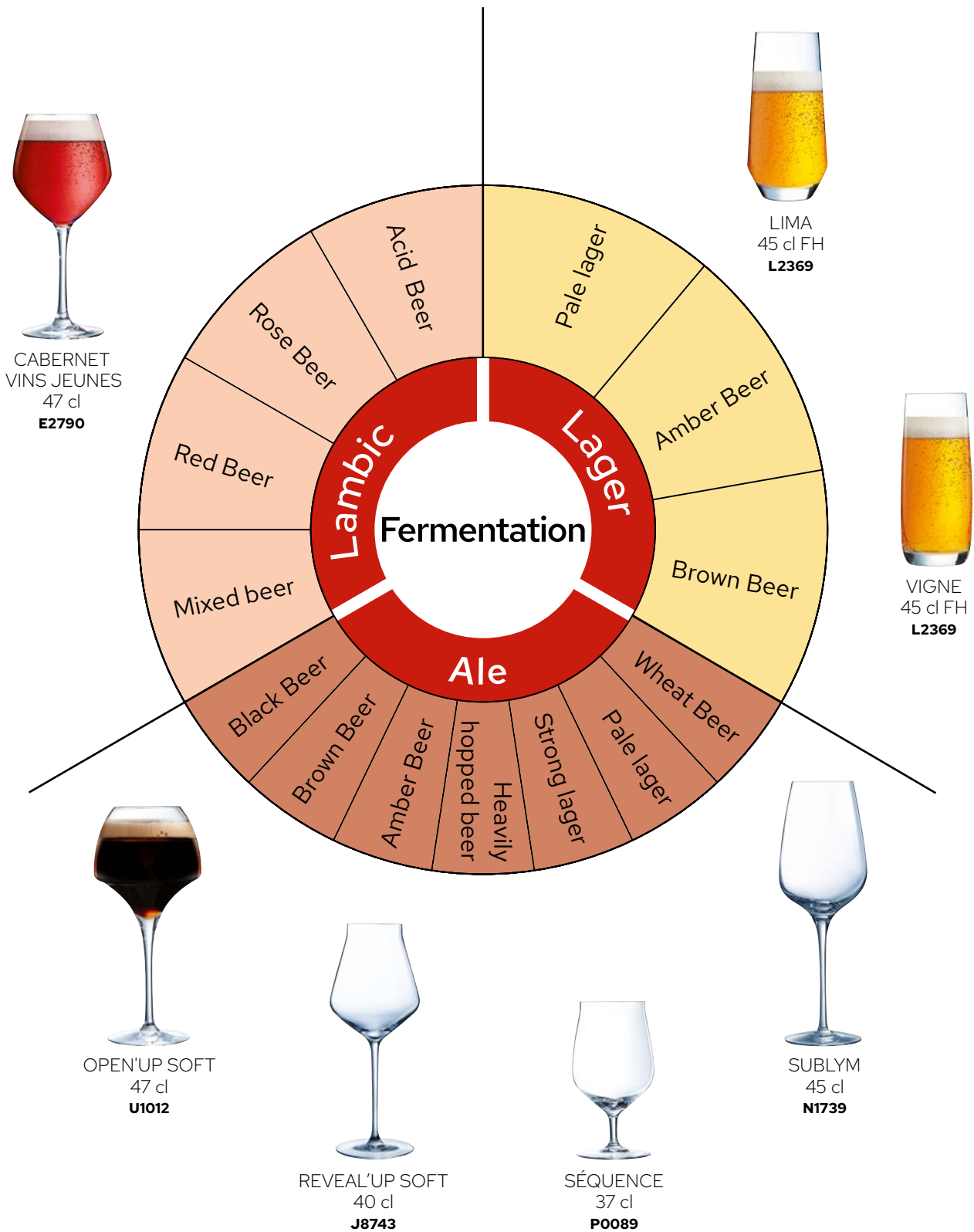

**Lambic:** Spontaneously fermented beer  
**Lager:** Low fermentation beer (low temperature)  
**Ale:** Top-fermented beer (high temperature)

# SPIRITS



COGNAC STEMGLASS



P 80

LIQUOR STEMGLASS



P 82

WHISKY STEMGLASS



P 83 - 84





≈ 10 cl

OPEN'UP SPIRIT  
39 cl ARDENT

Ø M = 105 mm  
H = 130 mm  
W = 170 g

**U1059**



Open'Up Spirit





SPIRITS  
70 cl COGNAC  
Ø M = 115 mm  
H = 165 mm  
W = 200 g  
**N8172**





SPIRITS  
6,5 cl CORDIAL

---

Ø M = 56 mm  
H = 160 mm  
W = 105 g  
**N 8213**



SPIRITS  
11 cl CORDIAL

---

Ø M = 60 mm  
H = 200 mm  
W = 90 g  
**N 8212**



SPIRITS  
12 cl SHERRY

---

Ø M = 60 mm  
H = 190 mm  
W = 80 g  
**N 8209**



SPIRITS  
10 cl GRAPPA

---

Ø M = 65 mm  
H = 180 mm  
W = 95 g  
**N 8211**



SPIRITS  
17 cl RHUM

---

Ø M = 75 mm  
H = 130 mm  
W = 105 g  
**N 6374**

## Open'Up Spirit

C&S **KRYSTA**

SHEER RIM

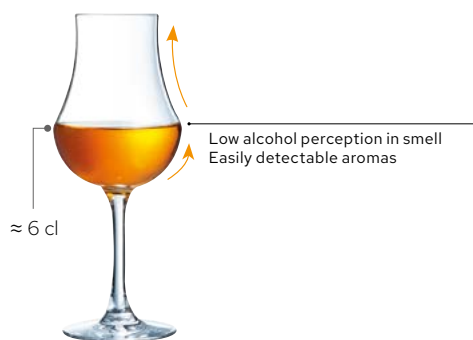

OPEN'UP SPIRIT  
16,5 cl AMBIENT

Ø M = 70 mm  
H = 170 mm  
W = 105 g

**U1062**

## Séquence

C&S **KRYSTA**

SHEER RIM



SÉQUENCE  
21 cl PORTO

Ø M = 65 mm  
H = 190 mm  
W = 115 g

**N9696**

## Lima

C&S **KRYSTA**

SHEER RIM



LIMA  
35 cl FB

Ø M = 95 mm  
H = 85 mm  
W = 230 g

**G3367**

Lima





## Vigne

C&amp;S KRYSTA

SHEER RIM

VIGNE  
38 cl FB

Ø M = 95 mm  
H = 90 mm  
W = 380 g

**L2370**VIGNE  
31 cl FB

Ø M = 85 mm  
H = 85 mm  
W = 260 g

**G3666**VIGNE  
20 cl FB

Ø M = 75 mm  
H = 75 mm  
W = 220 g

**G3659**

## Open'Up Spirit

C&amp;S KRYSTA

SHEER RIM



≈ 7 cl

OPEN'UP SPIRIT  
30 cl WARM

Ø M = 100 mm  
H = 90 mm  
W = 160 g

**U1032****V0828** set of 2

Open'Up Spirit



## Architecte

 CRISTALLIN



ARCHITECTE  
32 cl FB

Ø M = 95 mm  
H = 100 mm  
W = 410 g

**V7387** set of 4

## Longchamp

 CRISTALLIN



LONGCHAMP  
32 cl FB

Ø M = 56 mm  
H = 95 mm  
W = 290 g

**L7555**

**V4700** set of 4

## Macassar

 CRISTALLIN



MACASSAR  
32 cl FB

Ø M = 95 mm  
H = 100 mm  
W = 430 g

**Q4337**

**V7377** set of 4

## Rendez-vous

 CRISTALLIN



RENDEZ-VOUS  
32 cl FB

Ø M = 90 mm  
H = 95 mm  
W = 390 g

**V7382** set of 4

# DECANTER



Deposits from mature wines must be removed by the sommelier in order to fully enjoy the treasures of the wine.  
A tribute to mature wines and sommeliers!

● Explore

● Abondance **NEW**



P 88



P 88

Enhancing the quality of young wines by accelerating their maturation is a daily task for sommeliers.  
Airing a wine in a decanter is an opportunity for the sommelier to start a conversation about the taste experiences he wants his guests to enjoy.

● Macaron

● Opening

● Open'Up



P 89



P 89



P 89





Macaron

Explore

C&S KRISTA

MOUTH BLOWN / DROP CONTROL



≈ 0,75 L

EXPLORE  
1,3 L

Ø M = 145 mm  
H = 325 mm  
W = 800 g

**V4667**

Abondance

C&S KRISTA

NEW

MOUTH BLOWN



≈ 0,75 L

ABONDANCE  
1,6 L

Ø M = 190 mm  
H = 235 mm  
W = 700 g

**V9689**





Macaron

C&S KRYSTA

MOUTH BLOWN / DROP CONTROL



≈ 0,75 L

MACARON  
2 L

Ø M = 165 mm  
H = 310 mm  
W = 700 g

**V6503**

Opening

C&S KRYSTA

MOUTH BLOWN / DROP CONTROL



≈ 0,75 L

OPENING  
0,9 L

Ø M = 210 mm  
H = 240 mm  
W = 700 g

**R0020**

Open'Up

C&S KRYSTA

MOUTH BLOWN / DROP CONTROL



≈ 0,75 L

OPEN'UP  
1,4 L

Ø M = 145 mm  
H = 315 mm  
W = 600 g

**D6653**

# PRODUCT INFORMATION

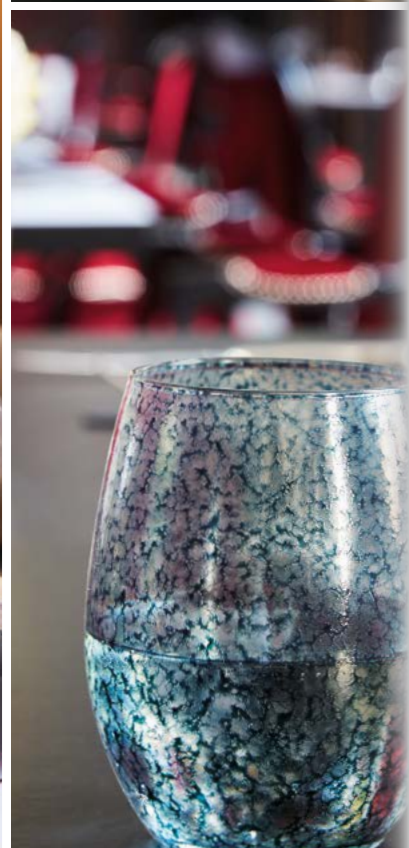

COLLECTION	SKU NUMBER	ITEM BAR CODE	INNER BAR CODE
ABONDANCE	V9689	0883314027587	0883314027587
ABSOLUTY	Q9217	0883314907681	0883314907735
	Q9216	0883314907674	0883314907728
	Q9214	0883314907650	0883314907704
	Q9215	0883314907667	0883314907711
ARCHITECTE	V7386		0883314988291
	V7387		0883314988307
CABERNET	14798	0026102259023	0026102980217
	46888	0026102259078	0026102469514
	46961	0026102259191	0026102469668
	46973	0026102259207	0026102469774
	46978	0026102260012	0026102469798
	46981	0026102259290	0026102469941
	47017	0026102470176	0026102470183
	47019	0026102259382	0026102470213
	47026	0026102470268	0026102470275
	48024	0026102259894	0026102466070
	53468	0026102259412	0026102534694
	D0795	0026102259801	0026102879184
	D0796	0026102259818	0026102879191
	E5358	0883314339895	0883314084474
	FJ035	0883314505009	0883314504996
	FJ036	0883314505023	0883314505016
	FJ037	0883314505047	0883314505030
	FJ038	0883314510775	0883314505054
	G3570	0883314340044	0883314189322
	G3573	0883314340112	0883314189353
CABERNET VINS JEUNES	E2788	0883314132083	0883314050257
	E2789	0883314340129	0883314050264
	E2790	0883314132090	0883314050271
CHAMPAGNE & COCKTAIL ...	N6815	0883314290745	0883314290769

COLLECTION	SKU NUMBER	ITEM BAR CODE	INNER BAR CODE
... CHAMPAGNE & COCKTAIL	N6831	0883314259520	0883314670776
	V3263	0883314684469	0883314684476
	N6887	0883314290868	0883314670950
	L3678	0883314518498	0883314518504
	Q7785	0883314891942	0883314891935
	Q3702	0883314848694	0883314848700
DISTINCTION	Q9064	0883314905984	0883314905991
	Q9062	0883314905946	0883314905953
	Q8990	0883314905120	0883314905137
	Q9080	0883314906226	0883314906233
ÉVIDENCE	V2821	0883314943429	0883314943436
	V2620	0883314943405	0883314943412
	V2822	0883314943443	0883314943450
	V3234	0883314948295	0883314948301
EXALTATION	V6719	0883314984781	0883314984798
	V6189	0883314975819	0883314975826
	V6190	0883314975833	0883314975840
	V6191	0883314975857	0883314975864
	Q1151	0883314823677	0883314823684
	Q9945		0883314915655
	Q0818	0883314819748	0883314819755
EXPLORE	V4667	0883314961614	0883314961614
LADY DIAMOND ...	L9742	0883314591538	0883314591521
	V8228		0883314959857
	L9743	0883314591552	0883314591545
	V4483		0883314959864
	L9744	0883314591576	0883314591569
	V4484		0883314959871
	L9747	0883314591637	0883314591620
	V4485		0883314959888
	L9746	0883314591613	0883314591606

COLLECTION	SKU NUMBER	ITEM BAR CODE	INNER BAR CODE
... LADY DIAMOND	V5468		0883314968293
LIMA	G3367	0026102131817	0026102857069
	G3368	0026102131770	0026102857045
	L2356	0883314503401	0883314503418
	L8110	0883314571769	0883314571776
LONGCHAMP	L7553	0883314564280	0883314564273
	V4705		0883314961881
	L7550	0883314564235	0883314564228
	V4704		0883314961874
	L7552	0883314564266	883314564259
	V4702		0883314961850
	L7555	0883314564327	0883314564310
	V4700		0883314961836
	L9757	0883314591835	0883314591828
	V7383		0883314988253
	L9754	0883314591774	0883314591767
	L9756	0883314591811	0883314591804
	MACARON	L9267	0883314586763
L9348		0883314586824	0883314586831
L9412		0883314586787	0883314586794
L9414		0883314586800	0883314586817
N0834		0883314605143	0883314605150
V6503		0883314606751	0883314606751
MACARON FASCINATION	N6386	0883314665536	0883314665543
MACASSAR ...	Q4335	0883314552676	0883314552683
	V7373		0883314988147
	Q4331	0883314552720	0883314552737
	V7374		0883314988154
	Q4346	0883314552706	0883314552690
	V7375		0883314988161
	Q4340	0883314552775	0883314552782

COLLECTION	SKU NUMBER	ITEM BAR CODE	INNER BAR CODE
... MACASSAR	V7376		0883314988178
	Q4337	0883314552942	0883314552959
	V7377		0883314988185
OPEN'UP	D6653	0026102256138	0026102256138
	U1008	0026102274576	0026102293355
	U1010	0026102900246	0026102878521
	Q8625		0883314901368
	U1011	0026102900635	0026102879238
	U1012	0026102900840	0026102878552
	U1013	0026102900451	0026102878545
	U1033	0883314028461	0883314028294
	U1041	0883314258899	0883314256017
OPEN'UP SPIRIT	U1051	0026102880623	0026102878514
	U1032	0883314083361	0883314084245
	U1059	0883314105308	0883314119749
	U1062	0883314083255	0883314084238
OPENING	R0020	0026102892084	0026102892084
PRIMARY	G0036	0026102259511	0026102116524
	G3322	0026102259610	0026102116203
	G3323	0026102259306	0026102116142
	L8677	0883314578218	0883314578225
PRIMARY COLOR	L9406	0883314586633	0883314586640
	L9407	0883314586657	0883314586664
	V3051	0883314946413	0883314946420
	V3052	0883314946444	0883314946482
PRIMARY HANDCRAFT	Q3478	0883314846126	0883314846133
	Q3477	0883314846102	0883314846119
	Q3215	0883314846201	0883314846218
RENDEZ-VOUS ...	V7378		0883314988192
	V7379		0883314988208
	V7380		0883314988215



COLLECTION	SKU NUMBER	ITEM BAR CODE	INNER BAR CODE
... RENDEZ-VOUS	V7381		0883314988239
	V7382		0883314988246
REVEAL'UP	J8742	0883314465655	0883314465662
	J8743	0883314465600	0883314465617
	Q8623		0883314901337
	J8907	0883314465563	0883314465570
	J8908	0883314465587	0883314465594
	J9014	0883314465679	0883314465686
	N1738	0883314465624	0883314465631
SENSATION EXALT	E7695	0883314340075	0883314118520
	E7696	0883314340099	0883314118537
	E7697	0883314340082	0883314118544
	E7698	0883314339963	0883314118551
	E7700	0883314339970	0883314118568
SÉQUENCE	L9947	0883314594379	0883314594386
	L9948	0883314594393	0883314594409
	L9949	0883314594416	0883314594423
	L9950	0883314594430	0883314594447
	L9951	0883314594454	0883314594461
	N9696	0883314701456	0883314701463
	N9710	0883314701630	0883314701647
	N9711	0883314701654	0883314701661
	P0089	0883314704952	0883314704969
	P3787	0883314744842	0883314744859
SPIRITS	N6374	0883314689570	0883314689587
	N8172	0883314684094	0883314684100
	N8209	0883314684353	0883314684360
	N8211	0883314684384	0883314684391
	N8212	0883314684407	0883314684414
	N8213	0883314684421	0883314684438
SUBLYM ...	L2609	0883314508253	0883314508246

COLLECTION	SKU NUMBER	ITEM BAR CODE	INNER BAR CODE
... SUBLYM	L2761	0883314508239	0883314508222
	L2762	0883314508277	0883314508260
	N1739	0883314508215	0883314508208
	V3604	0883314508185	0883314508178
SWIRLY	N5368	0883314661484	0883314661491
	V2829	0883314943528	0883314943535
	V2820		0883314943382
	V2830		0883314943559
SYMÉTRIE	V2831		0883314943573
	Q8707	0883314902174	0883314902181
	V2696	0883314941982	0883314941999
	V0391	0883314920321	0883314920338
	V1483	0883314931549	0883314931556
	V1171	0883314931730	0883314931747
	V2697	0883314942002	0883314942019
VIGNE	V1375	0883314931570	0883314931587
	G3658	0026102259269	0026102466988
	G3659	0026102259221	0026102467534
	G3666	0026102258941	0026102472149
	G3674	0026102258927	0026102468050
	L2369	0883314503678	0883314503685
	L2370	0883314503692	0883314503715
VIN AU VERRE	J4587	0883314418415	0883314526875
	P8619	0883314946420	0883314795844
	P9026	0883314800074	0883314800081

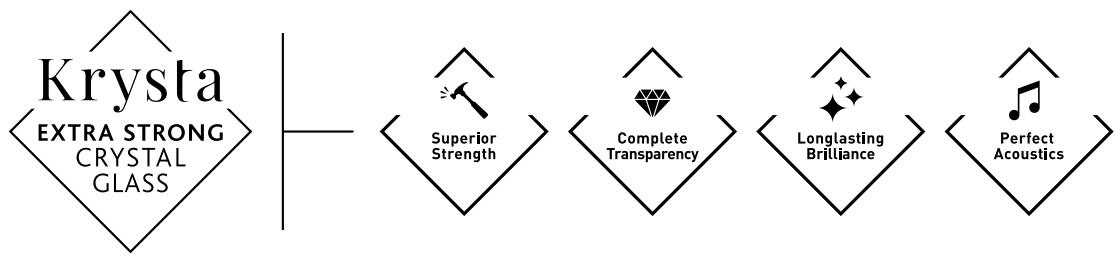

Gastronomy professionals are searching for glasses that satisfy their needs in terms of **perfection and sophistication**.

Their desire: Splendidly elegant table settings with **fine, lightweight, extremely transparent** products.

Their professional needs: **Intensive daily use** requires products that are **highly resistant to shocks and detergents**.

To meet these twin challenges of **aesthetic excellence and resistance**, the Arc Research Centre is introducing a **new generation of lead-free crystal**: **Krysta™**; The high-performance crystal glass.

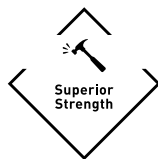

#### SUPERIOR STRENGTH

The Arc Research Centre has developed a crystalline material, Krysta™, combining **superior strength with exceptional finesse**.

Finer and stronger: the Krysta™ innovation.

With a thickness of 1.1 mm at the rim, Krysta™ is 30% stronger\*

- **Savings across the entire chain: fewer breakages and chipping during transportation, storage, washing and polishing.**

\*than other standard crystal glasses on the market.



#### COMPLETE TRANSPARENCY

Krysta™ is one of the **purest and most transparent crystal glass** on the market.

The perfect mastery of its composition, the quality of the sand used, and fusion at a very high temperature gives Krysta™ perfect transparency.

- **Tables enhanced by the sparkle of Krysta™.**
- **The visual aspects of every wine respected to perfection.**



#### LONGLASTING BRILLIANCE

Krysta™ boasts extreme, long-lasting brilliance.

After 2,000 professional dishwasher cycles, Krysta™ is **as brilliant and transparent as ever**.

- **Glasses that bring a special brilliance to your tables.**
- **Dinner services with lasting sparkle that you will be using for a long time.**



#### PERFECT ACOUSTICS

Krysta™'s exclusive composition gives it a **clear, pure sound** in keeping with the tone of the finest crystals.

- **The allure of Krysta™: A unique shine coupled with a distinct sound for a refined sensory experience.**

GA

## How to wash my glasses ...

Machine washing is recommended! All our glasses are made of:

### I do ...

- 1** I prefer to use "CLASSIC" products, in tablet, gel or powder form. I take care not to overdose.
- 2** I regulate the dishwasher by recording the hardness of my water. This value will be sent to me by my local council (TH: 5 to 7°f on average).
- 3** I make sure that the regenerating salt and the rinsing liquid (of the same brand as the tablet) are always available.
- 4** In my dishwasher...

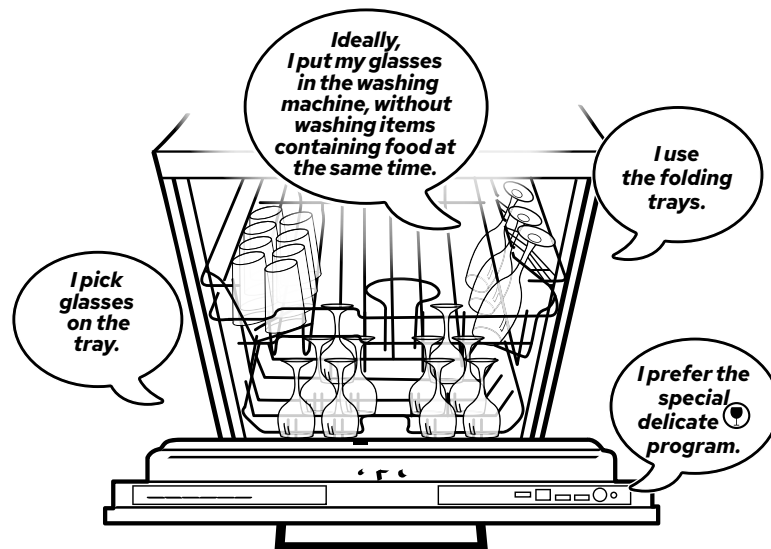
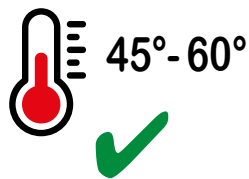

## Tips for storing my glasses ...

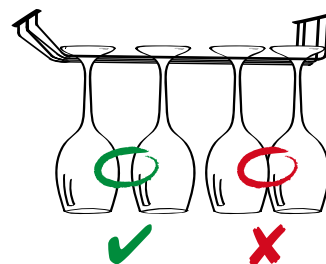
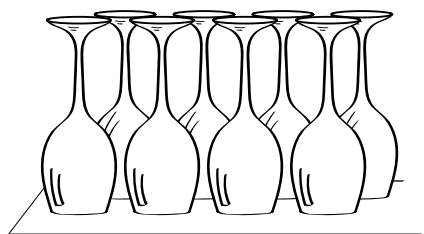

Avoid stacking, as this prevents scratches.

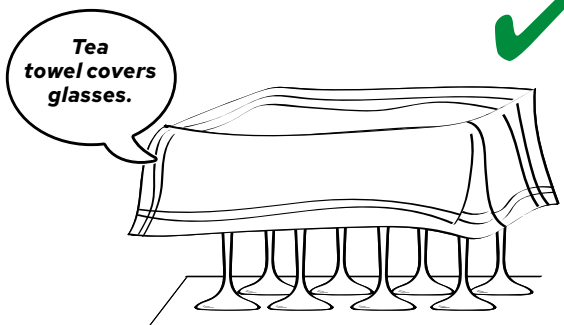
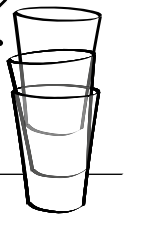



# Advice...

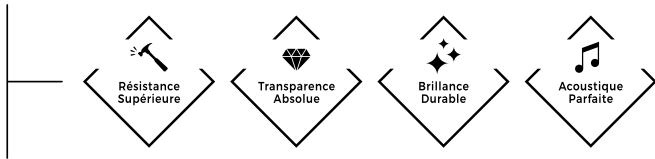

## I don't do ...

- 1** If I use "ALL-IN-ONE" tablets, I don't add regenerating salt or rinse aid, even if the indicator light stays on!
- 2** I don't use "ALL-IN-ONE" products if I have a softener, as this would bleach my glasses beyond repair.
- 3** I avoid using "All-in-one" products in areas with a lot of limestone, because the amount of salt won't be high enough and my glasses could develop limescale deposits.
- 4** In my dishwasher...

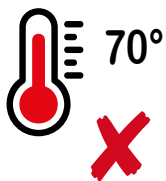

*To avoid iridescent deposits on my glasses, I don't wash them with (household) (cutlery) (rivets) (silver)....metal ustensils*

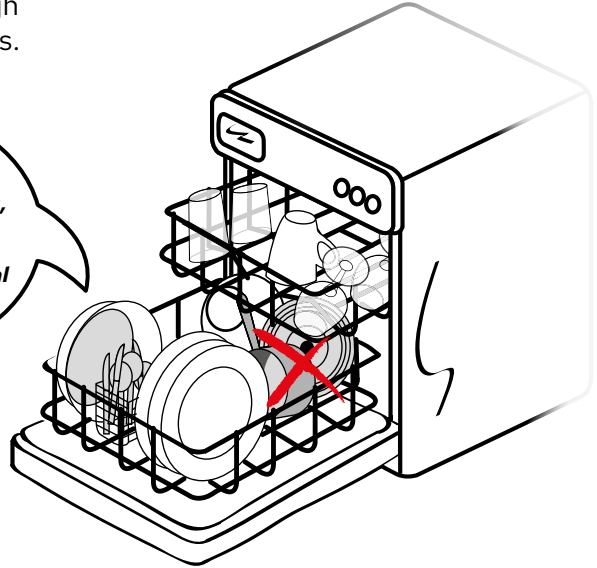

## If I buy one size, I choose...

The most versatile glass, including for sparkling wines.

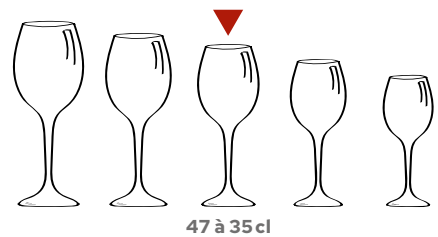

## If I use a glass every day, which one should I choose?

**Pro Tasting** : perfect for young red, rosé or white wines.  
Its short base allows it to fit the top rack of my dishwasher.



— CRÉATEUR D'EXPÉRIENCES —

CRÉATEUR D'EXPÉRIENCES  
DRINKWARE COLLECTION 2025

